

TOTAL SOLUTIONS™



TOTAL SPEAKER SOLUTIONS

TSS-500
Owner's Guide
(230V)



CAUTION
RISK OF ELECTRIC SHOCK
DO NOT OPEN

CAUTION: To reduce the risk of electric shock, do not remove cover (or back). No user-serviceable parts inside. Refer servicing to qualified service personnel.

CAUTION: To prevent electric shock, do not use this (polarized) plug with an extension cord, receptacle or other outlet unless the blades can be fully inserted to prevent blade exposure.

 The lightning flash with arrowhead symbol, within an equilateral triangle, is intended to alert the user to the presence of uninsulated "dangerous voltage" within the product's enclosure that may be of sufficient magnitude to constitute a risk of electric shock to persons.

 The exclamation point within an equilateral triangle is intended to alert the user to the presence of important operating and maintenance (servicing) instructions in the literature accompanying the appliance.

Declaration of Conformity

CE

We, Harman Consumer Group International
2, route de Tours
72500 Chateau du Loir
France

declare in own responsibility that the products described in this owner's manual are in compliance with technical standards:
EN 61000-6-3:2001
EN 61000-6-1:2001

Laurent Rault
Harman Consumer Group International
Chateau du Loir, France 1106

Satellites and center channel

Declaration of Conformity

CE

We, Harman Consumer Group International
2, route de Tours
72500 Chateau du Loir
France

declare in own responsibility that the product described in this owner's manual is in compliance with technical standards:
EN 55013:2001+A1:2003
EN 55020:2002+A1:2003
EN 61000-3-2:2000
EN 61000-3-3:1995+A1:2001
EN 60065:2002

Laurent Rault
Harman Consumer Group International
Chateau du Loir, France 1106

Powered subwoofer

read first! Important Safety Precautions!

- 1. Read Instructions.** All the safety and operating instructions should be read before the product is operated.
- 2. Retain Instructions.** The safety and operating instructions should be retained for future reference.
- 3. Heed Warnings.** All warnings on the product and in the operating instructions should be adhered to.
- 4. Follow Instructions.** All operating and use instructions should be followed.
- 5. Water and Moisture.** The product should not be used near water – for example, near a bathtub, washbowl, kitchen sink, laundry tub, in a wet basement, or near a swimming pool, and the like.
- 6. Accessories.** Do not place this product on an unstable cart, stand, tripod, bracket, or table. The product may fall, causing serious injury to a child or adult, and serious damage to the product. Use only with a cart, stand, tripod, bracket, or table recommended by the manufacturer, or sold with the product. Any mounting of the product should follow the manufacturer's instructions, and should use a mounting accessory recommended by the manufacturer.
- 7. Wall or Ceiling Mounting.** The product should be mounted on a wall or ceiling only when and as recommended by the manufacturer.
- 8. Ventilation.** Slots and openings in the cabinet are provided for ventilation and to ensure reliable operation of the product and to protect it from overheating, and these openings must not be blocked or covered. The openings should never be blocked by placing the product on a bed, sofa, rug, or other similar surface. This product should not be placed in a built-in installation such as a bookcase or rack unless proper ventilation is provided or the manufacturer's instructions have been adhered to.
- 9. Heat.** The product should be situated away from heat sources such as radiators, heat registers, stoves, or other products that produce heat. If placed near an amplifier, check with the manufacturer for applicability.

- 10. Power Sources.** This product should be operated only from the type of power source indicated on the marking label. If you are not sure of the type of power supply to your home, consult your product dealer or local power company. For products intended to operate from battery power, or other sources, refer to the operating instructions.
- 11. Grounding or Polarization.** This product may be equipped with a polarized alternating-current line plug (a plug having one blade wider than the other). This plug will fit into the power outlet only one way. This is a safety feature. If you are unable to insert the plug fully into the outlet, try reversing the plug. If the plug should still fail to fit, contact your electrician to replace your obsolete outlet. Do not defeat the safety purpose of the polarized plug.
- 12. Power-Cord Protection.** Power-supply cords should be routed so that they are not likely to be walked on or pinched by items placed upon or against them, paying particular attention to cords at plugs, convenience receptacles, and the point where they exit from the product.
- 13. Cleaning.** Unplug this product from the wall outlet before cleaning. Do not use liquid cleaners or aerosol cleaners. Use a damp cloth for cleaning.
- 14. Nonuse Periods.** The power cord of the product should be unplugged from the outlet when left unused for long periods of time.
- 15. Lightning.** For added protection for this product during a lightning storm, or when it is left unattended and unused for long periods of time, unplug it from the wall outlet and disconnect the antenna or cable system. This will prevent damage to the product due to lightning and power-line surges.
- 16. Overloading.** Do not overload wall outlets, extension cords, or integral convenience receptacles, as this can result in a risk of fire or electric shock.

17. Object and Liquid Entry. Never push objects of any kind into this product through openings, as they may touch dangerous voltage points or short-out parts that could result in a fire or electric shock. Never spill liquid of any kind on the product.

- 18. Damage Requiring Service.** Unplug this product from the wall outlet and refer servicing to qualified service personnel under the following conditions:
 - a. The power-supply cord or the plug has been damaged; or
 - b. Objects have fallen, or liquid has been spilled into, the product; or
 - c. The product has been exposed to rain or water; or
 - d. The product does not operate normally when following the operating instructions. Adjust only those controls that are covered by the operating instructions, as an improper adjustment of other controls may result in damage and will often require extensive work by a qualified technician to restore the product to its normal operation; or
 - e. The product has been dropped, or the enclosure damaged; or
 - f. The product does not appear to operate normally or exhibits a marked change in performance.

- 19. Attachments.** Do not use attachments not recommended by the product manufacturer, as they may cause hazards.
- 20. Replacement Parts.** When replacement parts are required, be sure the service technician has used replacement parts specified by the manufacturer or that have the same characteristics as the original part. Unauthorized substitutions may result in fire, electric shock or other hazards.

21. Safety Check. Upon completion of any service or repairs to this product, ask the service technician to perform safety checks to determine that the product is in proper operating condition.

22. Servicing. Do not attempt to service this product yourself, as opening or removing covers may expose you to dangerous voltage or other hazards. Refer all servicing to qualified service personnel.

TSS-500 OWNER'S GUIDE

Table of Contents

ii	Important Safety Precautions
1	Introduction
1	Unpacking the System
1	Planning Your System
2	Placement
2	Wall-Mounting the Satellites
3	TSS-500 Wall-Mounting
4	Center and Satellite Speaker Connections
5	Subwoofer Controls
6	Subwoofer Connections
7	Operation
7	Maintenance and Service
8	Specifications

INTRODUCTION

Infinity Total Solutions

Infinity Total Solutions continues Infinity's longstanding commitment to accurate sound reproduction. Our high-quality drivers, precision dividing networks and rigid, well-braced enclosures combine to deliver uncompromised performance in any multichannel home theater system.

In addition, these speakers, except for the powered subwoofer, are magnetically shielded for safe placement adjacent to a television.

Unpacking the System

Carefully unpack the system. If you suspect damage from transit, report it immediately to your dealer and/or delivery service. Keep the shipping carton and packing materials for future use. Open the package and verify the following contents:

- Warranty statement
- Wire package
 - Contains:
 - 2 x 12m (2 x 40') Speaker wire
 - 3 x 6m (3 x 15') Speaker wire
 - 1 x 4.5m (1 x 15') Subwoofer cable

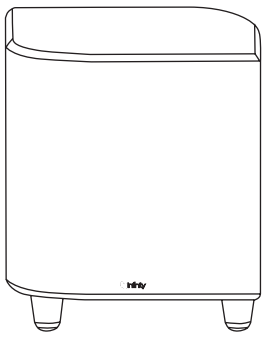

(1) Subwoofer



(1) Center with base

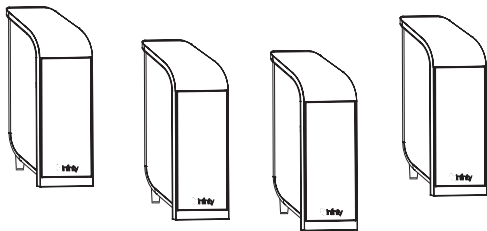

(4) Satellite speakers

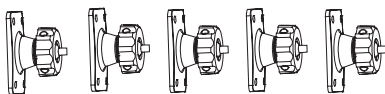

(5) Wall brackets for satellites

PLANNING YOUR SYSTEM

Before deciding where to best place your speakers, survey your room and study Figures 1 and 2.

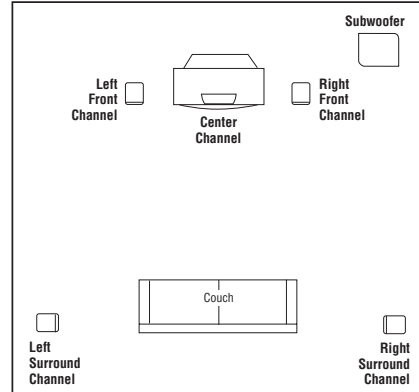

Figure 1. In this overhead view of a typical installation, satellite speakers are used to reproduce sound for the front and surround channels. The center channel reproduces sound and dialogue. The powered subwoofer provides bass for effects and music.

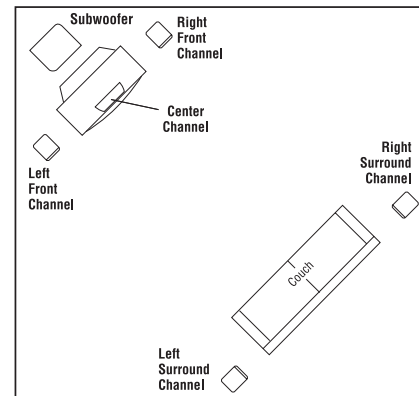

Figure 2. This figure shows an alternative layout, which may be more suitable for some rooms.

PLACEMENT

NOTE: The satellite speakers can be placed directly on a shelf, or mounted on a wall using the wall brackets included.

Left and Right Front Channels

For left and right front channels, place one satellite to the left and another to the right of the television, as shown in Figure 1.

Since the speakers are magnetically shielded, you can place them very close to the TV without worrying about the magnetic field distorting the picture.

Center Channel

For the center channel, place the speaker directly on top of, or below, your television. Use a shelf if the television does not provide a stable platform.

Surround Channels

For left and right surround channels, place one speaker on the left and another on the right, to the side of or slightly behind the listening area. The surround speakers should be mounted at a height of between 1.5 and 2 meters.

Subwoofer

Since the installation of a subwoofer can be somewhat more complicated than installing full-range speakers, it is essential that you read this section very carefully prior to connecting the subwoofer to your system. Should you have questions relating to installation, it is advisable to call either your dealer or Infinity's Customer Service Department for advice.

The performance of the subwoofer is directly related to its placement in the listening room and how you align the subwoofer with the satellite speakers. Setting the volume of the subwoofer in relation to the left and right speakers is also of critical importance because it is essential that the subwoofer integrate smoothly with the entire system. Setting the subwoofer's volume level too high will result in an overpowering, boomy bass. Setting the volume level too low will negate the benefits of the subwoofer.

Here are several additional facts on installation that may prove useful. It is generally believed that low frequencies (below 125Hz) are nondirectional and, therefore, placement of a subwoofer within any listening room is not critical. While in theory it is true that the larger wavelengths of extremely low frequencies are basically nondirectional, the fact is that, when installing a subwoofer within the limited confines of a room, reflections, standing waves and absorptions generated within the room will strongly influence the performance of any subwoofer system. As a result, specific location of the subwoofer becomes important, and we strongly recommend that you experiment with placement before choosing a final location. Placement will depend upon your room (for example, whether or not your room permits placement of the subwoofer near either satellite) and the amount and quality of bass required.

Mounting on Floor Stands

An optional TSS-Stand 500 floor stand is available, should you prefer to place your TSS-500 satellites on the floor; see your dealer or visit www.infinitysystems.com for more information.

In addition, there is a 1/4"-20 insert in each satellite that allows the satellite to be mounted to many third-party floor stands. Unscrew the rear foot to reveal the insert.

WALL-MOUNTING THE SATELLITES

The TSS-500 satellites are designed to be mounted on the wall.

There is a wall bracket for each satellite speaker.

Each speaker bracket will require (4) 1-1/2," #10 wood screws; each screw should be fastened to a wall stud. If a wall stud is unavailable, install an anchor appropriate for a 1-1/2," #10 screw.

NOTE: The customer is responsible for the correct selection and use of mounting hardware (available through hardware stores) that will ensure the proper and safe wall-mounting of the speakers.

WALL-MOUNTING (CONT.)

Step 1. Satellites only: Detach shelf stand by removing screw in rear of speaker.

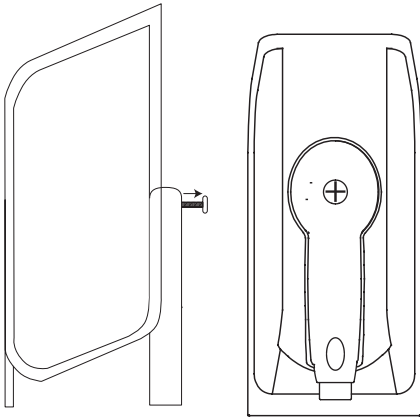

Step 2. Mark the positions on the wall where you would like to place the mounting screws.

Step 3. Place bracket against the wall and fasten four 1-1/2" #10 wood screws through the bracket's screw holes into the wall. If a wall stud is not available, use an appropriate anchor.

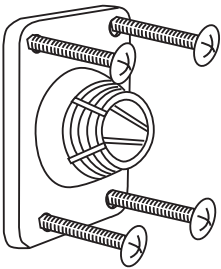

Step 4. Unscrew round collar (C) from bracket (A).

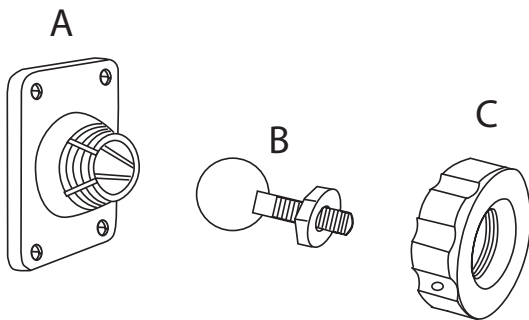

Step 5. Screw the ball and shaft assembly (B) to 1/4"-20 insert on rear of speaker. Back out 1/2 of a turn and tighten nut against the speaker.

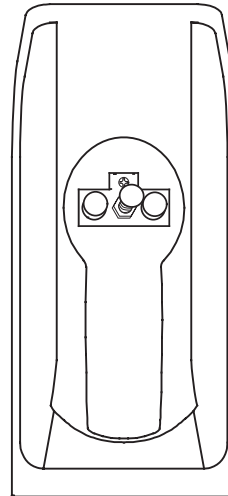

Step 6. Attach speaker wire as shown on page 4.

Step 7. Drop round collar (C) over ball and shaft assembly (B) that is mounted to the speaker with the finished side of the collar facing the rear of the speaker.

Step 8. Carefully push the ball straight into the socket mounted on the wall, angle the speaker as desired and tighten the collar using the enclosed metal bar.

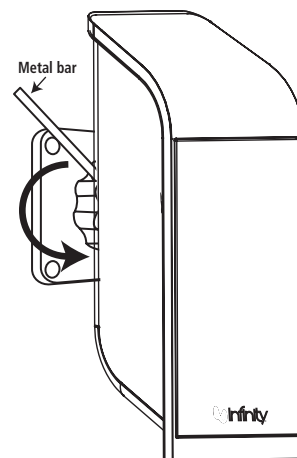

Figure 3. Bracket on wall.

CENTER AND SATELLITE SPEAKER CONNECTIONS

Turn Off All Power

After placing the speakers, you are ready to connect your system. First, turn off all audio-system power. Use high-quality speaker wire to make your connections. Speaker wire with polarity coding is included. For longer distances, heavier gauge wire is recommended. The side of the wire with a ridge or other coding is usually considered positive polarity (i.e., +). Also, consult the owner's manuals that were included with your amplifier or receiver to confirm connection procedures.

Satellites

Observe polarities when making speaker connections, as shown in Figure 4. Connect each + terminal on the back of the amplifier or receiver to the respective + (red) terminal on each speaker. Connect the – (black) terminals in the same way.

Important!

Do not reverse polarities (i.e., + to – or – to +) when making connections. Doing so will cause poor imaging and diminished bass response. Be certain that positive and negative wire strands are completely isolated to avoid short circuits that may damage your equipment.

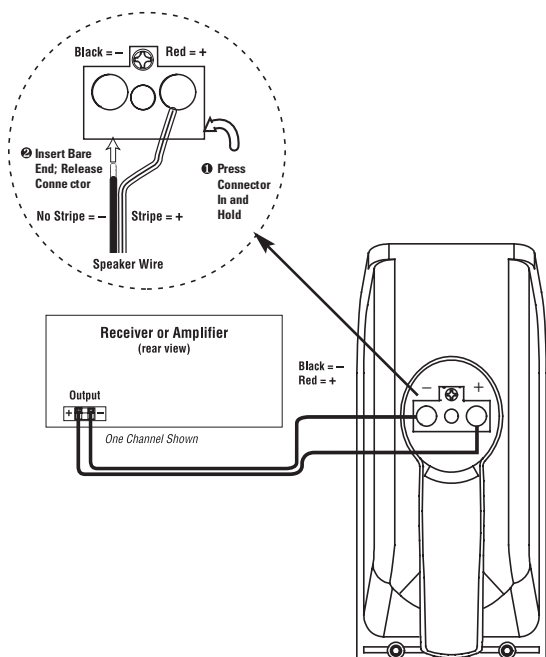

Figure 4. Wiring diagram shows polarity connections for one channel of a home theater system.

Center Channel

Observe polarities when making speaker connections, as shown in Figure 5. Connect each + terminal on the back of the amplifier or receiver to the respective + (red) terminal on the speaker. Connect the – (black) terminals in the same way.

Important!

Do not reverse polarities (i.e., + to – or – to +) when making connections. Be certain that positive and negative wire strands are completely isolated to avoid short circuits that may damage your equipment.

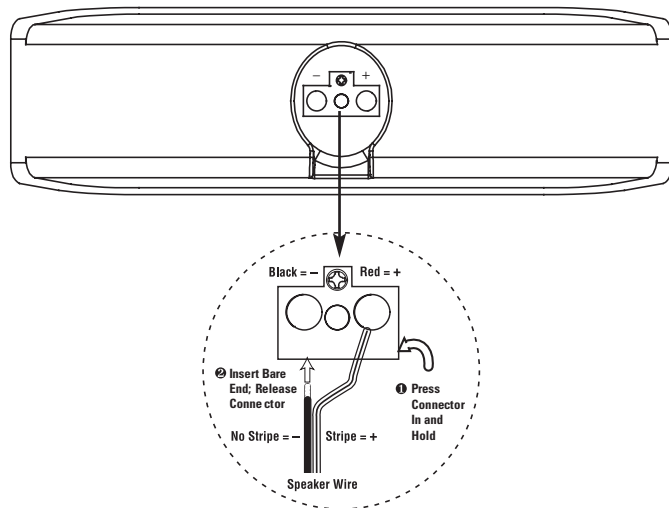

Figure 5. Wiring diagram shows polarity connections for a center channel.

SUBWOOFER CONTROLS

Rear Panel



- 1 Subwoofer Level Control
- 2 LFE Input
- 3 Line-Level Inputs
- 4 Power Switch

A Few Suggestions

We recommend that you do not operate your speakers or subwoofer with the bass, treble and loudness controls set to full boost. This will place undue strain on your electronics and speakers and could damage them.

The volume control setting on your processor/preamp or receiver is not a specific indication of the overall loudness level of the speakers. The only important consideration is the loudness level at which the system can be played, regardless of where the volume control is set.

Always turn down the volume control setting on your processor/preamp or receiver when changing a cassette or CD, or switching inputs to AM or FM operation. Excessively loud transients (clicks or popping sounds) can damage the satellite speakers and possibly the subwoofer.

Important!

Whenever changing cables, pulling plugs, etc., ALWAYS TURN OFF ALL EQUIPMENT, including the subwoofer.

SUBWOOFER CONNECTIONS

If you have a Dolby* Digital or DTS® receiver/processor with a low-frequency-effects (LFE) or subwoofer output:

15' (4.6m) subwoofer cable included

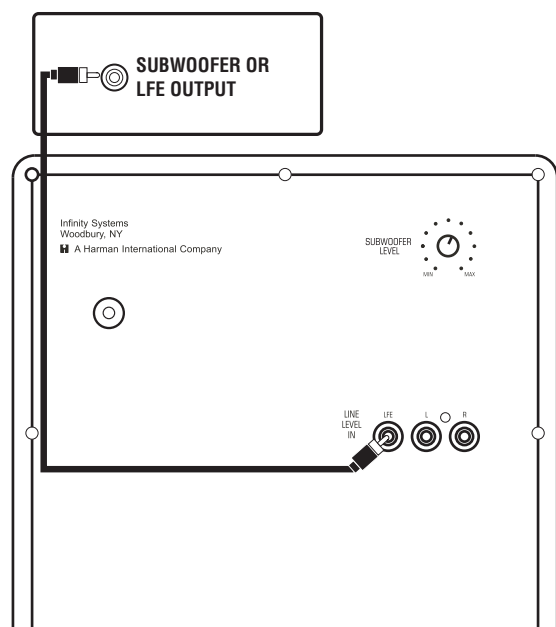

If your receiver/processor does not contain a Dolby Digital or DTS processor but has a subwoofer output:

15' (4.6m) subwoofer cable included

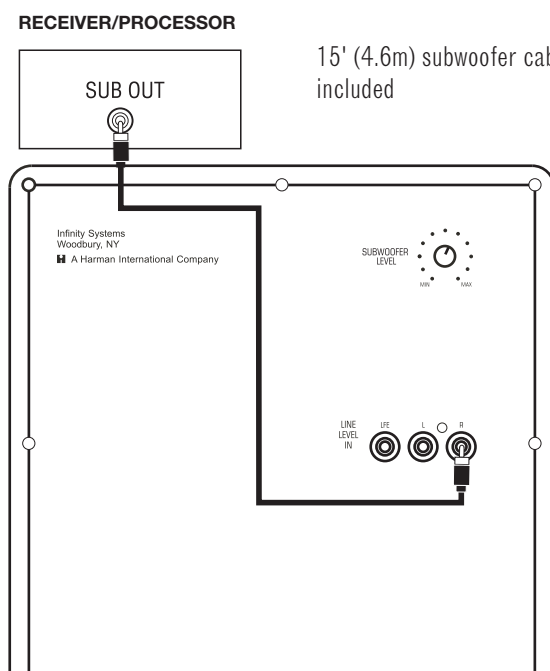

NOTE: If your receiver/processor has only one sub out, you may use either the L or R input.

OPERATION

Surround Modes

When using the TSS-500 in a Dolby* Digital or DTS home theater system, make sure all speakers are set to "Small". When using the system in a Dolby Pro Logic* home theater system, make sure the receiver's center channel mode is set to "Normal."

Some Dolby Digital-equipped receivers/processors offer different setup options for each source or surround mode, e.g., CD-stereo, videotape, Dolby, Pro Logic. In each case, follow your equipment's instructions to ensure that the subwoofer output is turned on and that the speakers are set to "Small" in each mode.

If your receiver has adjustable crossover settings, we recommend the subwoofer crossover be set between 100Hz – 120Hz.

Power On

Plug your subwoofer's AC cord into a wall outlet. Do not use the outlets on the back of the receiver.

Initially set the Subwoofer Level Control **1** to the "MIN" position.

Turn on the subwoofer by pressing the Power Switch **4** on the rear panel.

Turn on your entire audio system and start a CD or movie sound-track at a moderate level.

Auto On/Stand-By

With the Power Switch **4** in the ON position, the LED on the back panel will remain lit in red or green to indicate the On/Stand-By mode of the subwoofer.

RED = STAND-BY (No signal detected, Amp Off)

GREEN = ON (Signal detected, Amp On)

The subwoofer will automatically enter the Stand-By mode after approximately 10 minutes when no signal is detected from your system. The subwoofer will then power ON instantly when a signal is detected. During periods of normal use, the Power Switch **4** can be left on. You may turn off the Power Switch **4** for extended periods of nonoperation, e.g., when you are away on vacation.

Adjust Level

Turn the Subwoofer Level Control **1** up about half way. If no sound emanates from the subwoofer, check the AC-line cord and input cables. Are the connectors on the cables making proper contact? Is the AC plug connected to a "live" receptacle? Has the Power Switch **4** been pressed to the "On" position? Once you have confirmed that the subwoofer is active, proceed by playing a CD or DVD. Use a selection that has ample bass information.

Set the overall volume control of the receiver/processor to a comfortable level. Adjust the Subwoofer Level Control **1** until you obtain a pleasing blend of bass. Bass response should not overpower the room but rather be adjusted so there is a harmonious blend across the entire musical range. Many users have a tendency to set the subwoofer volume too loud, adhering to the belief that a subwoofer is there to produce lots of bass. This is not entirely true. A subwoofer is there to enhance bass, extending the response of the entire system so the bass can be felt as well as heard. However, overall balance must be maintained or the music will not sound natural. An experienced listener will set the volume of the subwoofer so its impact on bass response is always there but never obtrusive.

Final Positioning

After correctly connecting the TSS-500 system and verifying that both the subwoofer and all satellite speakers are playing, it is time to optimize the system for your particular listening room. Earlier, you placed the subwoofer in its general location. Finding the exact location for optimum performance sometimes only involves moving the speakers up to a few centimeters in any direction. We urge you, therefore, to experiment with placement, if possible, until your speakers deliver their full potential.

MAINTENANCE AND SERVICE

The satellite and subwoofer enclosures may be cleaned using a soft cloth to remove fingerprints or to wipe off dust.

All wiring connections should be inspected and cleaned or remade periodically. The frequency of maintenance depends on the metals involved in the connections, atmospheric conditions, and other factors, but once per year is the minimum.

If a problem occurs, make sure that all connections are properly made and clean. If a problem exists in one loudspeaker, reverse the connection wires to the left and right system. If the problem remains in the same speaker, then the fault is with the loud-speaker. If the problem appears in the opposite speaker, the cause is in another component or cable. In the event that your TSS-500 ever needs service, contact your local Infinity dealer or Infinity directly at www.infinitysystems.com for a service center near you.

SPECIFICATIONS

TSS-500

Frequency Range:	Satellites 150Hz – 25,000Hz (± 3 dB)	Center Channel 150Hz – 25,000Hz (± 3 dB)
Recommended Amplifier Power Range:	10 – 100 watts	10 – 100 watts
Sensitivity: (2.83V @ 1 meter)	86dB	87dB
Nominal Impedance:	8 Ω	8 Ω
Crossover Frequency:	7,000Hz	7,000Hz
Midrange Driver(s):	64mm (2-1/2") magnetically shielded	Dual 64mm (2-1/2") magnetically shielded
High-Frequency Driver:	19mm (3/4") magnetically shielded	19mm (3/4") magnetically shielded
Dimensions (H x W x D):	195mm x 89mm x 70mm (7-11/16" x 3-1/2" x 2-3/4")	89mm x 305mm x 70mm (3-1/2" x 12" x 2-3/4")
Weight:	0.5kg (1.2 lb)	0.9kg (1.9 lb)
	Powered Subwoofer 39Hz – 150Hz (± 3 dB)	
Frequency Range:	39Hz – 150Hz (± 3 dB)	
Amplifier Output:	100 watts RMS	
Low-Frequency Driver:	200mm (8")	
Crossover Frequency:	120Hz, 24dB/octave (line-level [non-LFE] input)	
Dimensions (H x W x D):	403mm x 346mm x 371mm (15-7/8" x 13-5/8" x 14-5/8")	
Weight:	14.4kg (31.7 lb)	

Infinity continually strives to update and improve existing products, as well as create new ones. The specifications and construction details in this and related Infinity publications are therefore subject to change without notice.



TECHNOLOGY • PERFORMANCE • DESIGN

© 2005 Harman International Industries, Incorporated. All rights reserved.

Infinity Systems, 250 Crossways Park Drive, Woodbury, NY 11797 USA www.infinitysystems.com

Infinity and Harman International are trademarks of Harman International Industries, Incorporated, registered in the United States and/or other countries.

Total Solutions is a trademark of Harman International Industries, Incorporated.

Dolby and Pro Logic are registered trademarks of Dolby Laboratories.

DTS is a registered trademark of DTS, Inc.

Part No. 406-000-05308-E 10/05

H A Harman International® Company